

Colorado State University Classroom AV Standards

Classroom Support Services – Academic Computing & Networking Services
Version 29MAR2021

Colorado State University seeks to create world-class academic spaces that enable learning of the highest caliber. This document encapsulates current thinking about academic technology delivering the best in-person and online learning environments. CSU Classroom Support Services should be consulted at all phases of the design and construction of new academic spaces for interpretation of these standards, and to pursue variation for innovative and creative approaches to the application of technology in the learning environment.

While this document reflects defined standards and is updated frequently, the hardware standards, listed on the last page, should be considered as always up to date regardless of the RFP process and requirements.

Contents

- General Description..... 4
 - Standard 4
 - Optional..... 4
- Conference Rooms 5
- Basic Control System 5
 - Switcher Video Outputs 5
 - Switcher Audio Outputs 5
- HCDP Management..... 5
- Lectern..... 6
 - Design 6
 - Service Access 6
 - Mounting..... 6
 - Accessories 6
 - Rack Mounting 16
 - Power and Data..... 16
- Cabling..... 16
- Monitor Wall Mounting 17
- Lecture Capture..... 17
 - Camera 17
 - User Control Panel Camera Confidence/Setup Page 17
 - Program Source..... 17
 - Power, Ethernet and Mounting 17
 - Microphone..... 17

Projectors	17
Selection	17
Setup	17
Mounting.....	18
Security.....	18
Projector Screens	18
Selection	18
Display Devices Shutdown Timer	18
Control Design	19
Crestron GUI Standards.....	19
Introduction	19
Options	20
Off / On Controls	21
Aspect Ratio	21
Wall Camera	21
Microphones	21
Requirements	21
Display Control	21
Screen O’Ride	22
Source Buttons	22
Displaying a Source in Matrix Mode	23
HDCP for User Devices HDMI and USB-C	24
Source Pop-up Control Pages.....	24
Lighting Controls	26
Display On/Off Control.....	27
Audio & Microphone Controls	27
Service Page	28
Panel Setup.....	29
Automatic Projector Shutdown.....	30
Monitor Displays	30
Audio	31
Network Design	31
Terminations and Connectors	32
Lighting	32
Commissioning	32
User Control Panel Checks	32
Controller / Switcher	33

Projector Checks.....	33
Lectern.....	33
Sign-Off.....	33
Device Serial Numbers	33
Review and Approval.....	33
Programs and Data Handoff.....	33
Diagrams and Additional Specifications.....	33
RFQ Submittal Requirements for AV Contractors.....	34
General	34
Industry Specific	34
Project Management.....	34
Parts List	34
16:10 Screens	34
Wireless Microphone	34
Controller	35
User Control Panel	35
Document Camera	35
DVD / Blu-Ray Player	35
Wireless Presentation	35
Audio DSP	35
Lecture Capture	35
Contacts.....	35
Classroom Support Services (CSS).....	35
Interim Manager of CSS	35
Figure 1 Cable Nook Junior Configuration	6
Figure 2 Large Lectern 1 of 5.....	7
Figure 3 Large Lectern 2 of 5.....	8
Figure 4 Large Lectern 3 of 5.....	9
Figure 5 Large Lectern 4 of 5.....	10
Figure 6 Large Lectern 5 of 5.....	11
Figure 7 Small Lectern 1 of 4.....	12
Figure 8 Small Lectern 2 of 4.....	13
Figure 9 Small Lectern 3 of 4.....	14
Figure 10 Small Lectern 4 of 4.....	15
Figure 11 Single Mode Page of the Dual Mode Program.....	19
Figure 12: Multi Mode Page of the Dual Mode Program.....	20
Figure 13: Display Off, Display On, Display Sleep, Aspect and Screen Over-Ride.....	21
Figure 14: Projector Warming and Cooling Lockouts Single Mode & Matrix Mode.....	Error! Bookmark not defined.
Figure 15: Inactive and Active Source Buttons	22

Figure 16: Displaying a Source in Matrix Mode	23
Figure 17: All Destinations with Selected Button Feedback	23
Figure 18: HDCP Indications for HDMI and USB-C Sources.....	24
Figure 19: Pop-up Setup Pages.....	24
Figure 20: Full-page Blu-ray/DVD Popup	25
Figure 21: Full-page Wall Camera Setup Pop-up	25
Figure 22: Full-page Wireless Media Setup Pop-up	26
Figure 23: Lighting controls All Deselected and All Selected	26
Figure 24: Audio Muted	27
Figure 25 Full-Size Password and Service Pages	28
Figure 26 Panel Setup > Audio Setup	29
Figure 27 Panel Setup > Display Setup	29
Figure 28 Panel Setup > Standby Timeout	29
Figure 29 Projector Auto-Off Sequence with Center Panel Flash	30
Figure 30 Projector on time extended notification.....	31

General Description

The CSU AV classroom is designed for consistent usability across all CSU classrooms and consists of these components and functionality:

Standard

- A two-rack-unit-wide lectern containing AV system and user equipment.
- A Crestron user control panel standalone-mounted on the lectern working surface.
- A Crestron controller/switcher
- Bring your own device (BYOD) support with HDMI, USB-C and Ethernet cables provided through a cable management inset.
- AC power provided at the lectern user working surface.
- A document camera centered on the user-right-side lectern working surface.
- A Blu-ray deck mounted at the top of the user-left-side lectern bay rack.
- Whiteboards on the front wall and also sometimes on side walls that leave a substantial amount of whiteboard space available even when the projection screens are fully lowered.
- Powered, medium gain projection screens with ceiling-recessed housings. Screens actuate automatically according to the projector power status.
- Display devices controlled by HDBaseT or RoomView Connected Display (Crestron).
- Latest projector and display technologies.
- Stereo-connected wall or ceiling-mounted speakers..

Optional

- Matrixed video on multiple display devices.
- 4K signal processing to 4K display devices.
- Outboard audio DSP.
- A lecture capture device that records all non-content-protected presentation sources, room camera, and presenter audio.

- Wireless BYOD presentation from the lectern.
- Wall-mounted monitors for additional display coverage.
- Breakout monitors for group sessions including a wireless presentation device and wall plate HDMI connection at each location.
Each breakout monitor input is routed to a matrix switcher allowing the display of any breakout monitor input or lectern source to any breakout monitor or main display.
- Wireless lapel microphone for room voice amplification.
- An additional hand-held microphone for multi-presenter room voice amplification.
- A lectern PC.
- Larger-scale installations may employ an AV closet if necessary.

Conference Rooms

- Standard video display is a wall-mounted video monitor, 65" or larger.
- All wall mounted monitors in conference rooms shall have user accessible controls either provided in a wall-mounted control box or a Crestron touch panel. The options on the control box or Crestron panel must include at least on/off, volume up/down and source input selection.
- Lecterns are generally not used in conference rooms, but there are exceptions. Check with CSU Classroom support to confirm.
- Connections to the monitor are generally routed via an HDMI cable from the conference table area to the monitor.

Basic Control System

Each classroom is comprised of current manufacturer shipments of:

- Controller – Crestron DM series.
- Touch Panel – Crestron 7"
- DSP, if necessary, is Extron DMP-64.

Switcher Video Outputs

- The video signal to the main display(s) must have the ability to be scaled.
- If a PC is installed into the lectern, then the lectern monitor is connected to it, not to a switcher video output.

Switcher Audio Outputs

- One line-level, variable stereo program output mixing analog and HDMI sources and the variable microphone level to the room's audio power amp.

HDCP Management

By default, HDCP is disabled on user input sources HDMI and USB-C.

HDCP to these sources will be enabled by pressing and holding the associated user control panel icon for three seconds.

- While enabled, an HDCP indicator for that source is displayed above the icon and flashes one second on/one second off.
- Subsequent source selections held less than three seconds disable all input HDCP.

Lectern

Design

CSU classrooms use a two rack-bay wooden lectern. Current lectern suppliers: CSU Facilities or Growling Bear Company of Greeley CO: 1-970-353-6964. *Note:* CSU will consider accessible lectern options – please consult with Classroom Support Services when specifying accessible lecterns in designs.

Service Access

Each lectern will have access panels or hinged doors to allow maintenance and repair, secured by a lockset (see parts list).

Mounting

- The lectern should be non-movable and bolted to the floor, typically using L-brackets.
- No immovable objects may be located within 36 inches of the user side of the lectern or within 30 inches of service access doors.

Accessories

- Rack frame providing 14 RU of rack space; one per lectern bay (see parts list).
- Cable nook for cable management shall be built into lectern top as shown in Figure 1 to provide an AC power outlet, HDMI, USB C and Ethernet cable (see parts list).

Install the Cablenook components with the AC outlets to the lectern rear.

The distance between Bar 1 and Bar 2 is close enough that the cable ends won't fall through and wide enough that the cables slide freely.

The AC outlets set immediately adjacent to Bar 2.

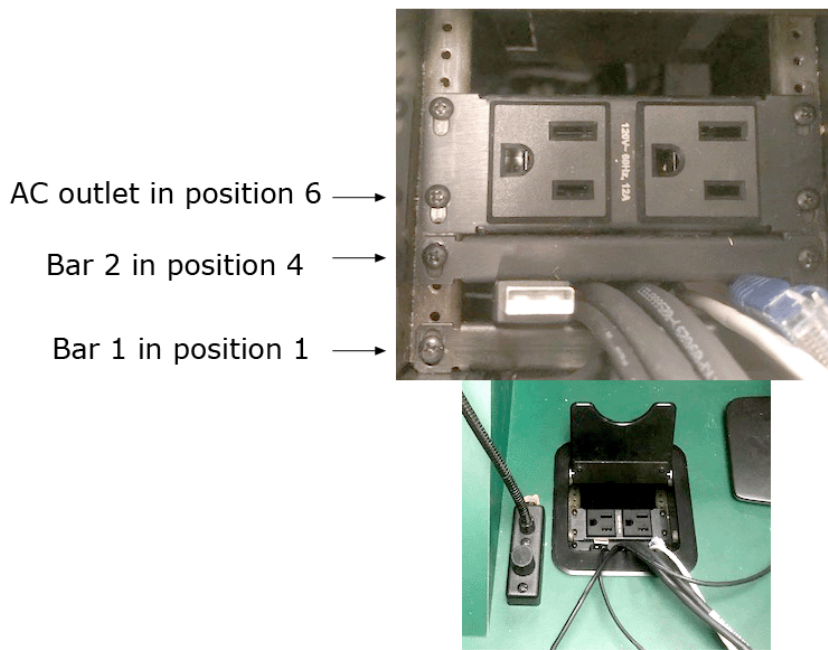

Figure 1 Cable Nook Junior Configuration

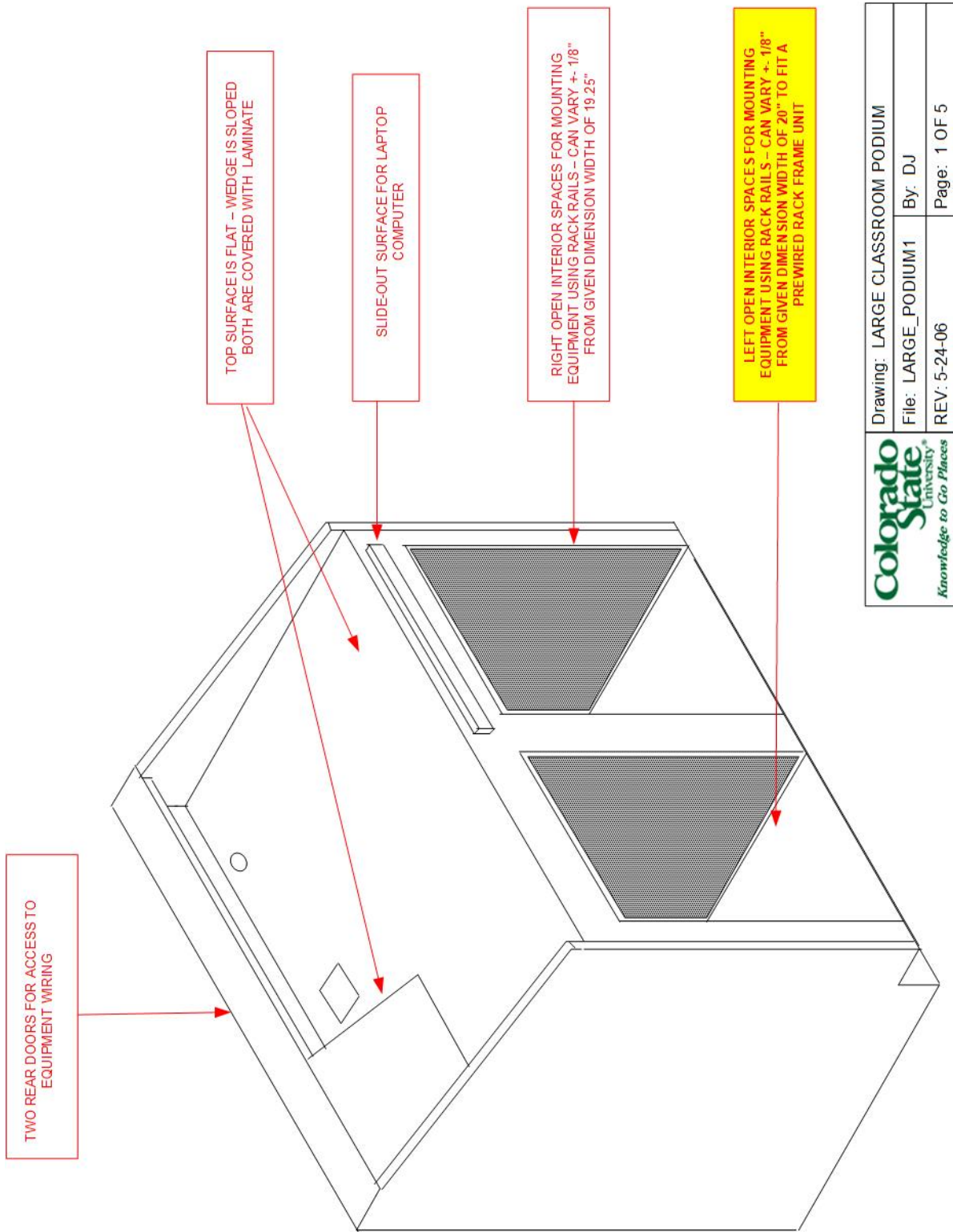
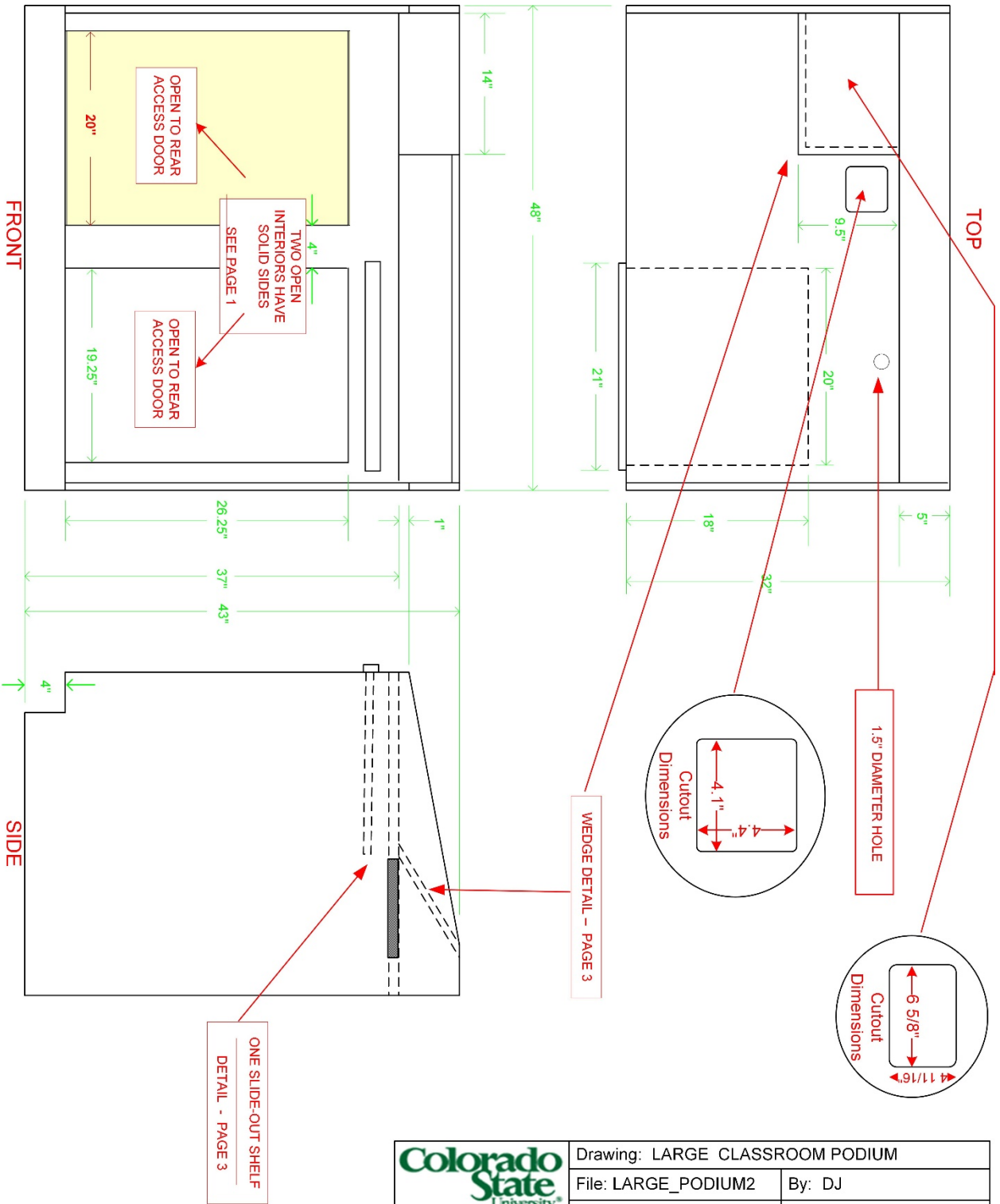

Figure 2 Large Lectern 1 of 5

	
Drawing: LARGE CLASSROOM PODIUM	By: DJ
File: LARGE_PODIUM1	REV: 5-24-06
Page: 1 OF 5	



	Drawing: LARGE CLASSROOM PODIUM	
	File: LARGE_PODIUM2	By: DJ
	REV: 5-24-06	Page: 2 OF 5

Figure 3 Large Lectern 2 of 5

WEDGE DETAIL -NTS

Fixture
Cutout
Centered in
Wedge

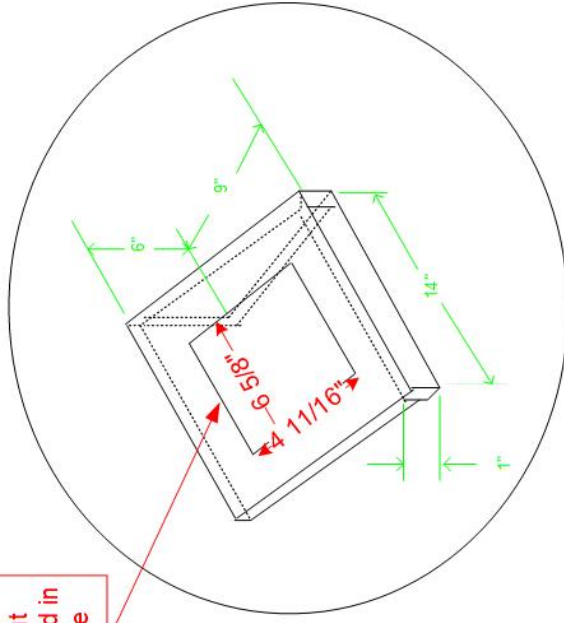

SLIDE OUT SHELF DETAIL

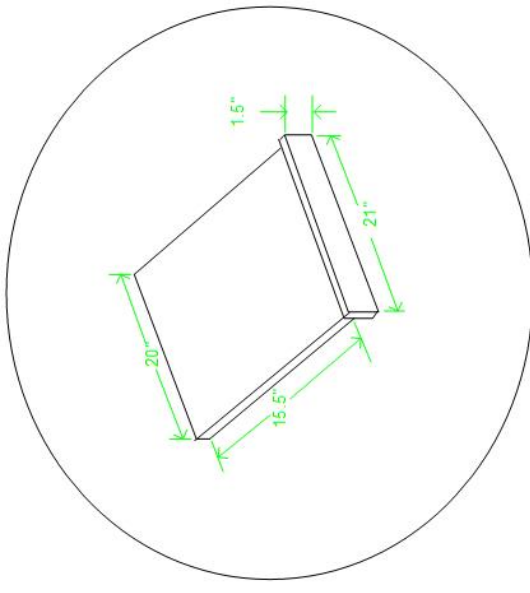

- MATERIALS:**
- All 3/4" Maple Plywood
 - Medium cherry stain with clear finish
 - Top flat surface and wedge top/sides to be covered with WILSONART D79-60 HUNTER GREEN laminate
 - Rear access door – Hinge hidden
Key lock only – no handle or latch
All Lectrums to be keyed alike with the following:
Stock Locks C8053-C415A-14A, disc tumbler, cam lock, bright nickel finish
 - Sliding shelf hardware to be 20-30 lb. capacity

Colorado State University
Office of Instructional Services

Contact :

Doug Satterfield
Clark A74
Voice: 491-6035
FAX: 491-6989

	Drawing: LARGE CLASSROOM PODIUM
	File: LARGE_PODIUM3 By: DJ
	REV: 5-24-06 Page: 3 OF 5

Figure 4 Large Lectern 3 of 5

Two Flush Access Doors Fit into Interior Openings
#415 Key Lock Only – No Handles

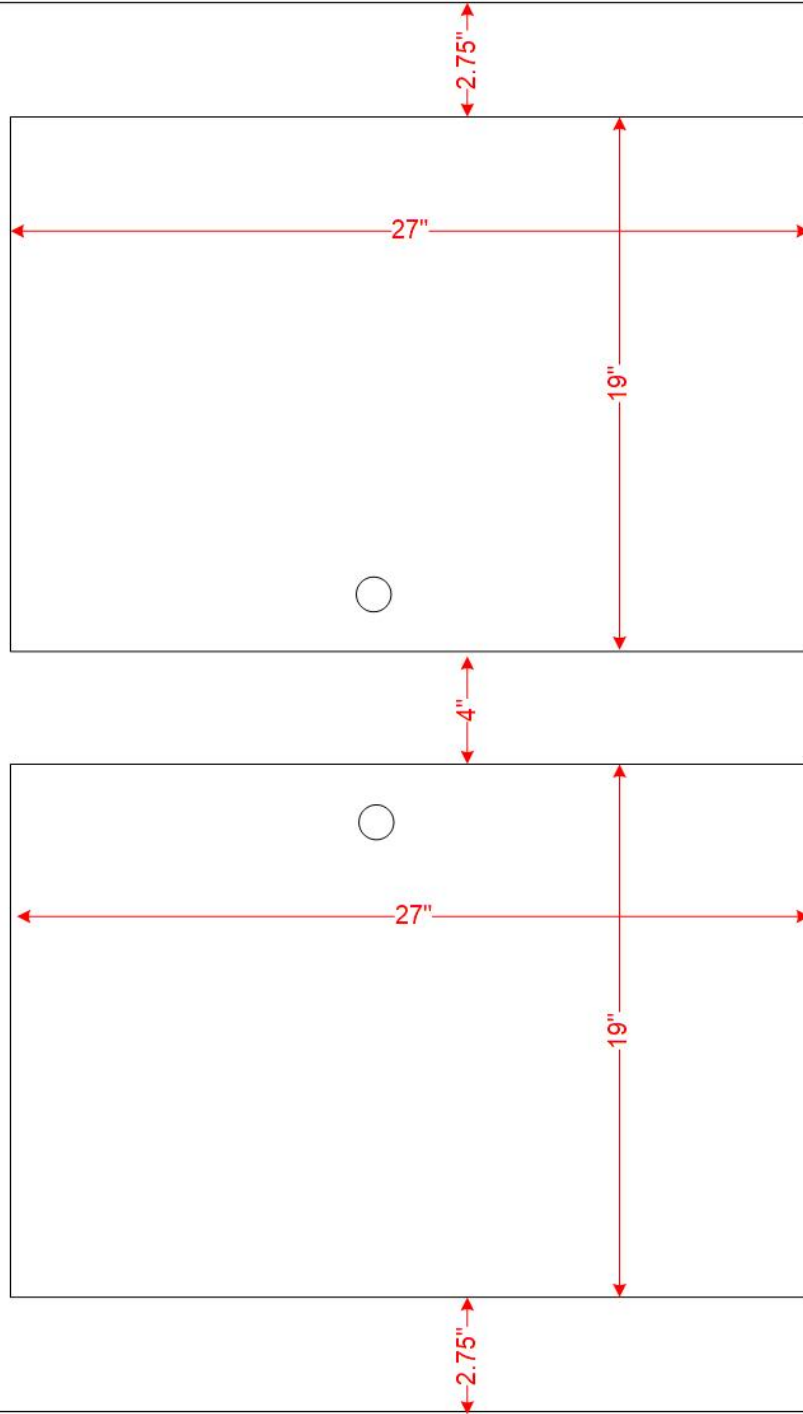

Figure 5 Large Lectern 4 of 5

 Colorado State University Knowledge to Go Places	Drawing: LARGE CLASSROOM PODIUM
File: LARGE_PODIUM4	By: DJ
REV: 5-24-06	Page: 4 OF 4

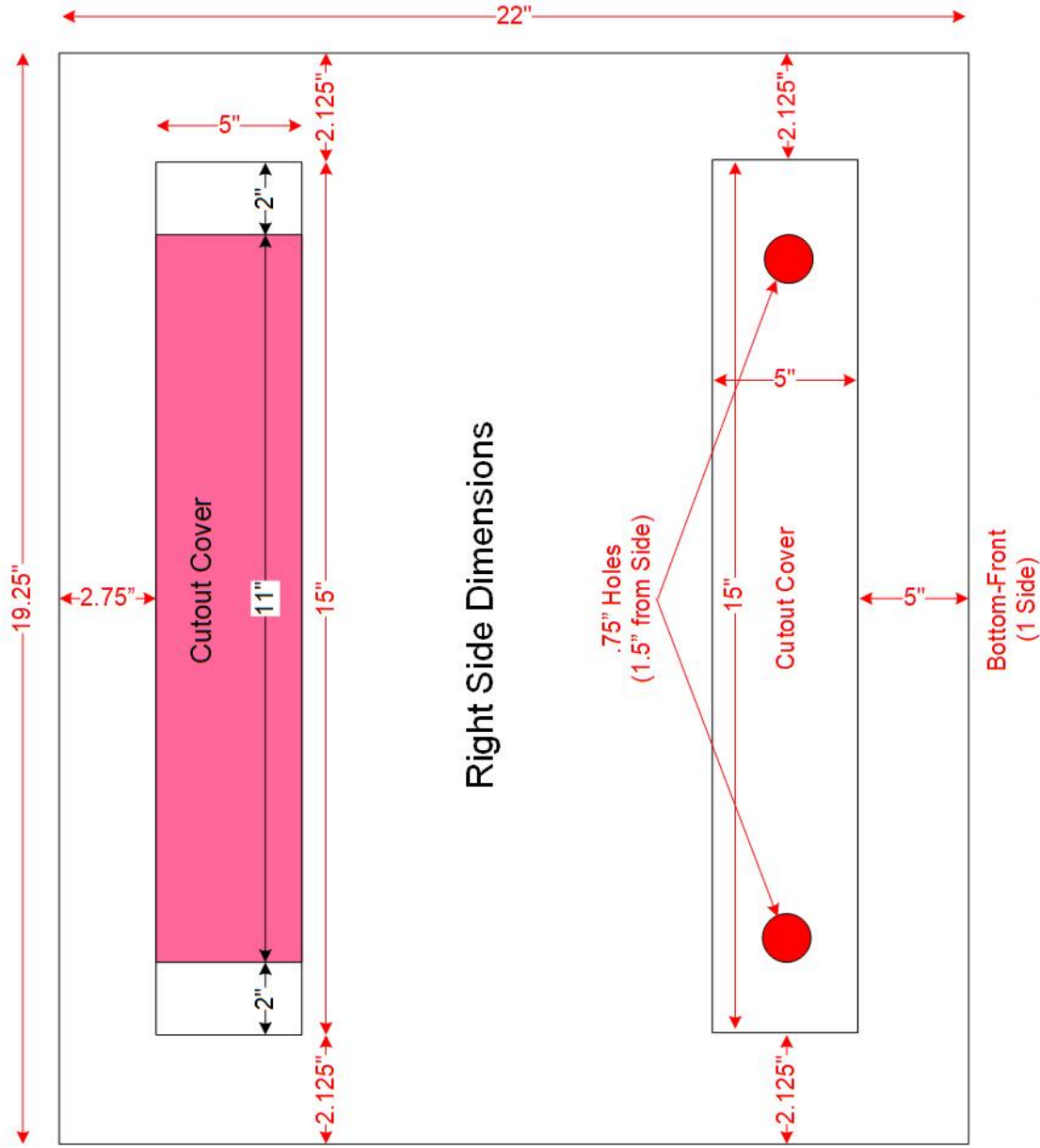

Figure 6 Large Lectern 5 of 5

	Drawing: LARGE CLASSROOM PODIUM
	File: LARGE_PODIUM5 By: DJ
	REV: 5-24-06 Page: 5 OF 5

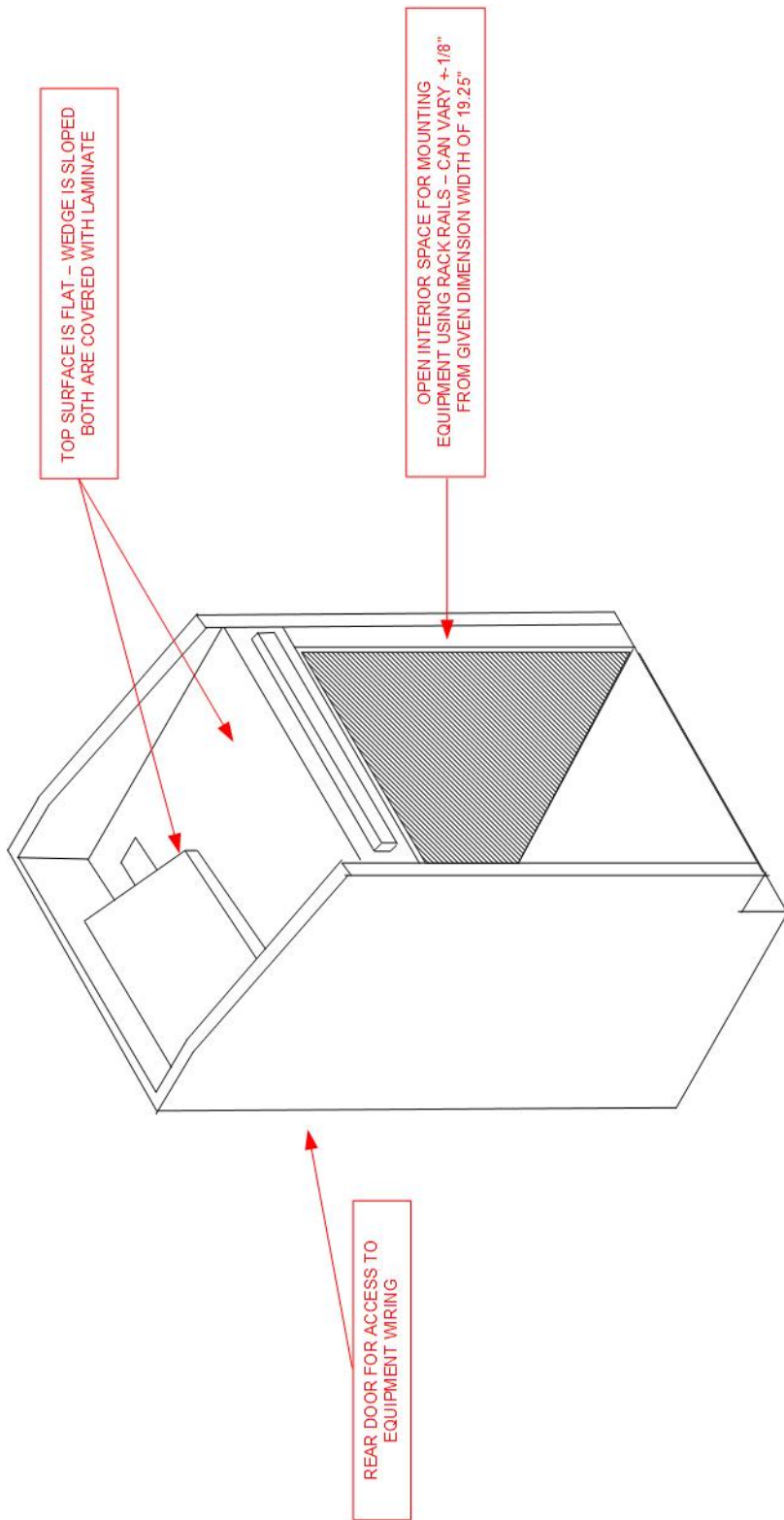
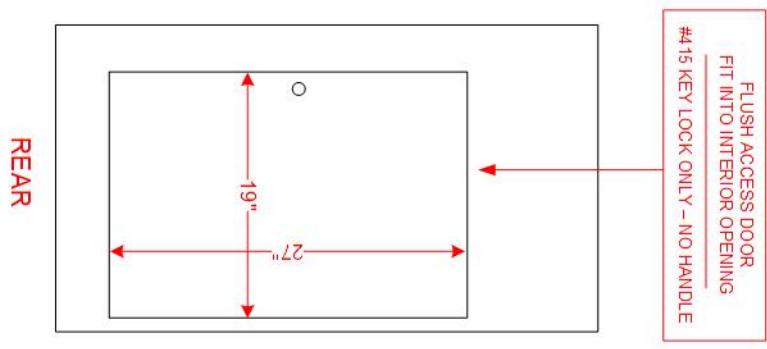
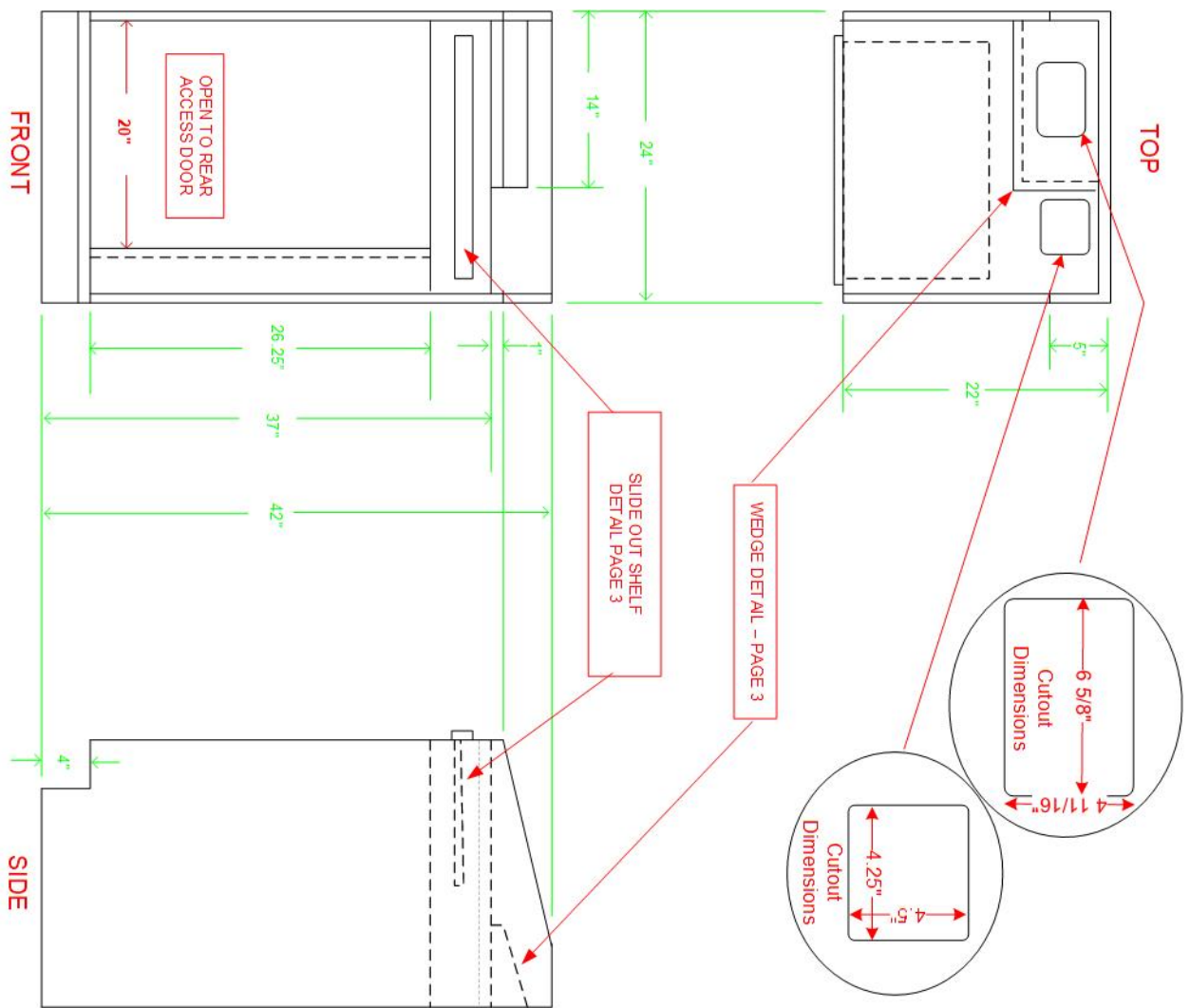

Figure 7 Small Lectern 1 of 4

 Colorado State University <i>Knowledge to Go Places</i>		Drawing: SMALL CLASSROOM PODIUM File: SMALL_PODIUM1 REV: 5-24-06
		By: DJ
		Page: 1 OF 4



	Drawing: SMALL CLASSROOM PODIUM	
	File: SMALL_PODIUM2	By: DJ
	REV: 5-24-06	Page: 2 OF 4

Figure 8 Small Lectern 2 of 4

WEDGE DETAIL -NTS



SLIDE OUT SHELF DETAIL

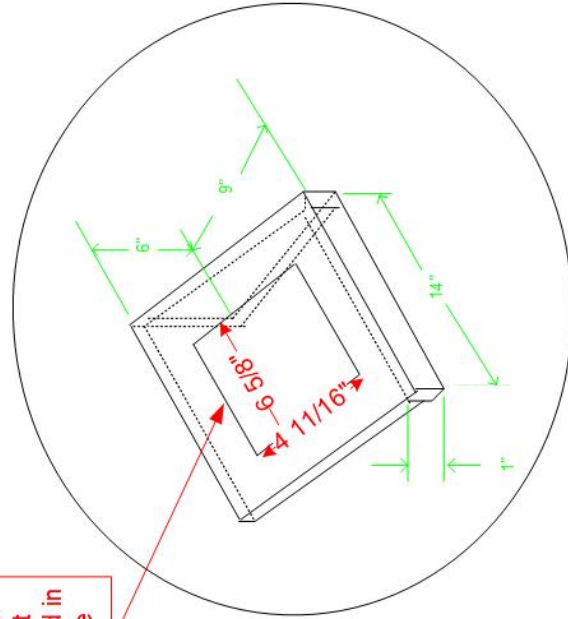
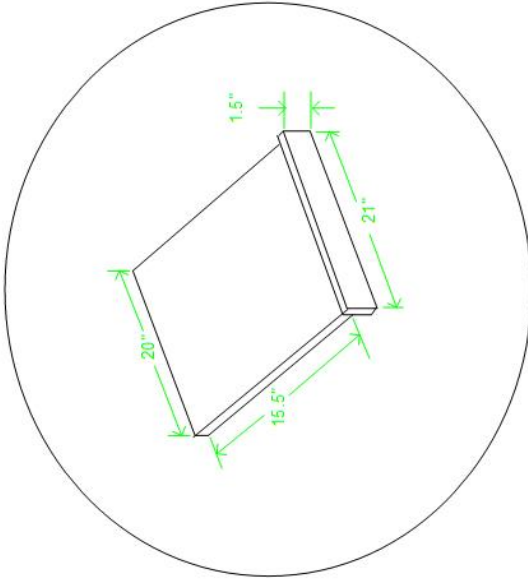

MATERIALS:

- All 3/4" Maple Plywood
- Medium cherry stain with clear finish
- Top flat surface and wedge top/sides to be covered with WILSONART D79-60 HUNTER GREEN laminate
- Rear access door – Hinge hidden
Key lock only – no handle or latch
All Lectrums to be keyed alike with the following:
Stock Locks C8053-C415A-14A, disc tumbler, cam lock, bright nickel finish
- Sliding shelf hardware to be 20-30 lb. capacity

Colorado State University
Office of Instructional Services

Contact :

Doug Satterfield
Clark A74
Voice: 491-6035
FAX: 491-6989



Drawing: SMALL CLASSROOM PODIUM	
File: SMALL_PODIUM3	By: DJ
REV: 5-24-06	Page: 3 OF 4

Figure 9 Small Lectern 3 of 4

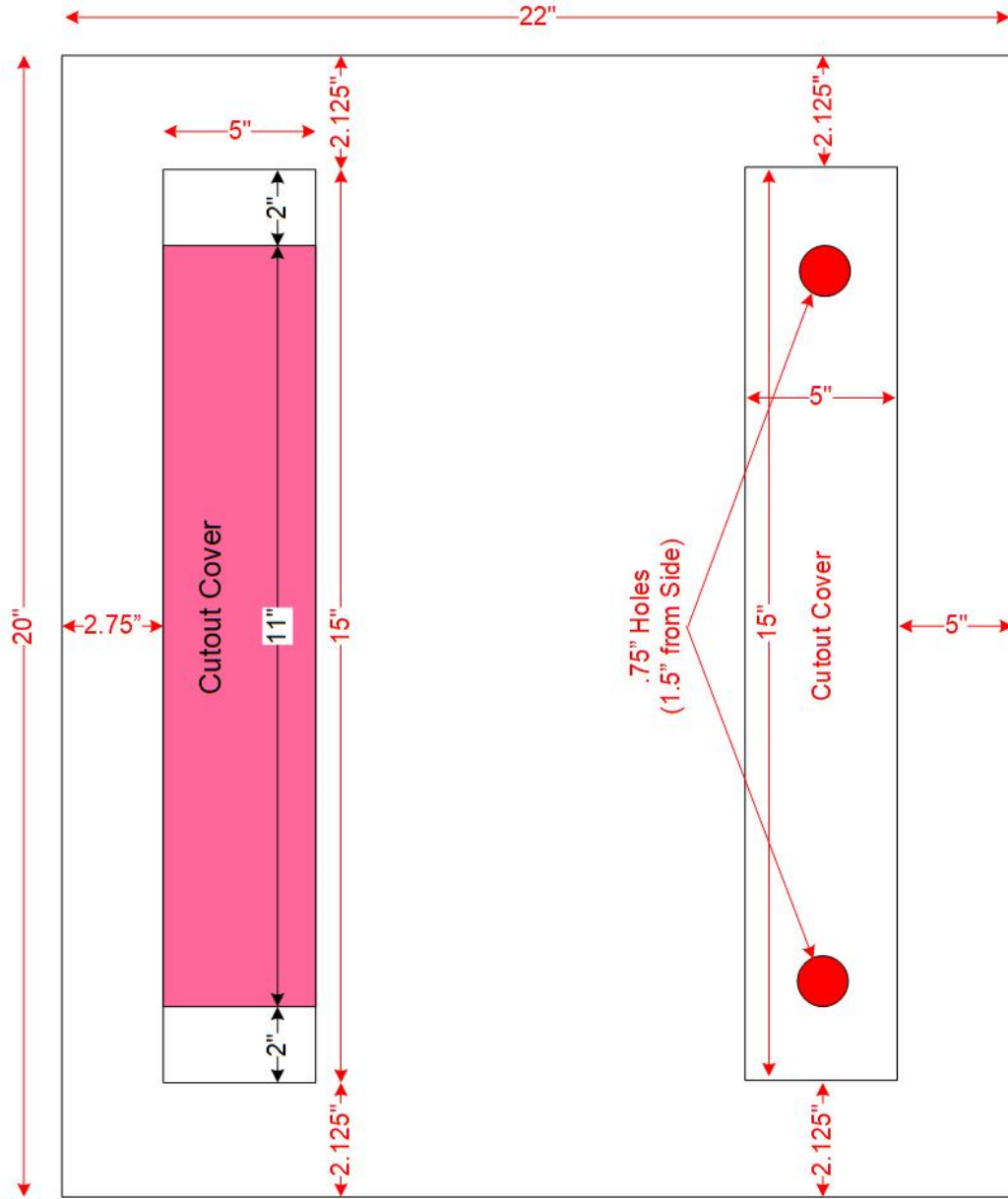

Figure 10 Small Lectern 4 of 4

Bottom-Front

		Drawing: SMALL CLASSROOM PODIUM
		File: SMALL_PODIUM5
		By: DJ
		Page: 4 OF 4
		REV: 5-24-06

Rack Mounting

- Locate lectern-mounted PCs and Blu-ray decks at or near the top left side of the lectern.
- Controls such as power switches and volume controls, and equipment interconnection cables or connections must be made inaccessible to users.
- At least one rack unit (1 RU) shall be provided between mounted equipment.
- Open rack space to be blocked off by either blank vented rack panels or 1/8" smoked polycarbonate (Lexan).
- If the electronic equipment fills only one rack, the open side of the lectern shall be equipped with either another rack frame or with rack rails on the front, to which blank rack plates or a 1/8" smoked polycarbonate (Lexan) panel shall be mounted, fully covering the space.

Power and Data

Power and Ethernet interfaces are available inside the lectern; never underneath.

- Use surge-protected power strips mounted near the service doors. Other power conditioners including sequencers are not used.
- Upon project completion, two unoccupied and unswitched power outlets will be available.
- A quad AC power box shall be provided on the rear of a sidewall in each lectern bay, on flex from a combined 20 amp circuit.
- One user network cable shall be provided from the lectern switch to the top surface of the lectern.

Cabling

- All video, data and control wires are to be labeled and numbered in correspondence with the system diagram.
- An as-built wiring diagram is to be placed inside the Lectern on the rear equipment side door, and the computer file with that wiring diagram is to be provided to Classroom Support Services.
- Proper wiring dress, maintenance loops, and cable separations are to be employed while omitting the use of zip ties to bind cables to the rack chassis. Velcro is acceptable.
- All wires connected from the lectern to ancillary equipment or connections are via conduit, core drill, or under a bolted down "tall-boy" threshold.
- Rework wiring routed to above the ceiling from the lectern shall be inside a surface-mount cable raceway with the portion traversing the wall resembling the color of the wall or be painted to match.
- Conduit cable pulls should not exceed 50% of the permissible conduit size.
- Nylon pull strings will be left in place after cables are pulled.
- All cables not routed through conduit are to be above the ceiling grid on J-hooks.
- Plenum cable is to be used on all plenum air spaces including ceiling and under raised floors.
- Lectern cable access shall be a 2-inch conduit installed in the floor, or equivalent cable space shall be provided for cable runs to the lectern.
- When video is transported over HDBaseT, cabling must be Crestron DM- or Extron XTP-rated.
- RS 232: See Parts List.
- Speaker: See Parts List.
- Install only Extron user cables for HDMI and USB C; no Crestron HDMI cables in the system.

Monitor Wall Mounting

- All wall-mounted monitors shall be controlled from the lectern Crestron controller and one additional HDMI input port must be provided below or adjacent to the monitor for individual user connection and input.
- AC power outlet located behind

Lecture Capture

Any classroom seating more than 50 students shall be equipped with a lecture capture system including microphone(s), camera, and connections to a digital recorder.

Camera

- A PTZ camera mounted on the wall opposite the lectern and presentation screen with no obstructions (for example, lights and columns).
- One camera per room.
- Camera video is streamed via RTSP to both the user control panel camera setup page and lecture capture recorder.
- Authentication is enabled.

User Control Panel Camera Confidence/Setup Page

- Classrooms designed with the camera image as a display source or where the size of a room allows for multiple camera shots will contain user-uneditable Close, Mid and Wide preset selections, PTZ controls and a camera image preview. Smaller rooms needing just one camera shot will contain only a camera image preview with the control system sending a command to refresh a desired preset approximately every 10 minutes.

Program Source

HDMI program video mimicking the primary room display shall be connected to the lecture capture device.

Program audio is provided over the HDMI connection.

Power, Ethernet and Mounting

Both power and Ethernet connections are to be supplied for a lecture capture recording device located on a rack shelf in the lectern.

Microphone

A lectern-mounted omni-directional boundary mic or one or more ceiling mounted digital microphones are used depending on the need for audience participation capture.

Projectors

Selection

- Crestron Connected capability required.
- Brightness in Lumens is to be
 - 5K ANSI lumens or higher for a small to medium size classrooms (30 - 50 students).
 - 7K ANSI lumens or higher for larger medium classrooms (above 50)
 - 10,000 ANSI lumens for auditorium sized classrooms.
- Laser; no replaceable lamps.
- 1920 x 1200 (16:10) standard resolution.

Setup

- Set up to auto-report on error using the internal mail server.

- SMTP server name: smtp.colostate.edu
- Mail from: [Bldg/room]projector@colostate.edu
- Send to: css_shared_mail@mail.colostate.edu
- No authentication

Mounting

- Projectors shall be mounted as high as practical in each room to reduce the potential for tampering. Typical mounting height is level with the top of the projection screen minimizing keystone effect and subsequent adjustments.
- Ceiling tile replacement type mounts are typically used in rooms with drop ceilings - **Premier PFCMA Ceiling Tile replacement** – secured to ceiling structure. Variable length **1.5” black iron pipe** is typical to drop the projector to proper position.
- All cables are routed through the 1.5” pipe – including power.
- A power outlet mounted on the projector mounting plate is standard.
- Projector mount is to be a universal mount by Chief manufacturing model **RPM-U Projector Mount (Key Code "A")**.

Security

- ¼” Aircraft type cable connected to the projector and secured in the ceiling with a pad lock.

Projector Screens

Selection

16:10 Screen by Dalite is standard in all new installations – model varies depending on the room size.

- Recessed electric screens are preferred in new installations and manual screens are sometimes used.
- Projectors shall be mounted so that the placement of room lighting systems does not interfere with the projected image.
- Multiple screens will be overridden individually via the user control panel.

Display Devices Shutdown Timer

Daily, a five-minute power-off sequence for display devices begins:

- Between 7 AM and 5 PM—with five hours of inactivity.
- After 5 PM until 7 AM—with three hours of inactivity.

The associated user control panel audio is set to maximum (key clicks set to 10 %).

Two audio recordings, **ding.mp3** and **LucyProjPwrOff60.mp3** are used with panel display shutdown ques.

The power off sequence is:

1. Concurrently, **ding** is played, and a flashing shutdown page is displayed that includes a timer counting down from five minutes.
The shutdown page provides button presses to allowing the user to either stop the shutdown sequence or shutdown immediately.
2. After two minutes, **ding** is played again while the shutdown page continues to flash.
3. After three minutes, **ding** is played again while the shutdown page continues to flash.
4. After four minutes, **LucyProjPwrOff60** is played warning the system will shutdown in 60 seconds.
5. After five minutes, the display devices are sent power-off commands.

Control Design

- All electric powered screens are to be controlled independently via the lectern touch panel and by wall-mounted control(s).
- Program audio shall be volume controlled and muted separately from the microphone audio.
- Audio level and mute controls and indicators for both room program and room microphone shall be on the main page of the user control panel.
- A password protected maintenance / service page shall be provided, with these features:
 - Panel setup access
 - Lift controls when applicable.
 - Timed executive mode enable for controller/switcher control, reverting to disabled after 30 minutes.

Crestron GUI Standards

Here are appearance and operation standards for user touch panels at Colorado State University.

The intention is to provide a common user experience across campus.

Representative program files built using Crestron's Simpl Windows and VTPro applications are available for reference.

Introduction

Dual mode programs are leveraged for both single and multi mode classrooms.

- Single mode means the same source is displayed simultaneously on one or more display devices.
- Multi mode means any source can be selected for selective display on two or more display devices.

Any layout with a multi mode page will also have a single mode page.

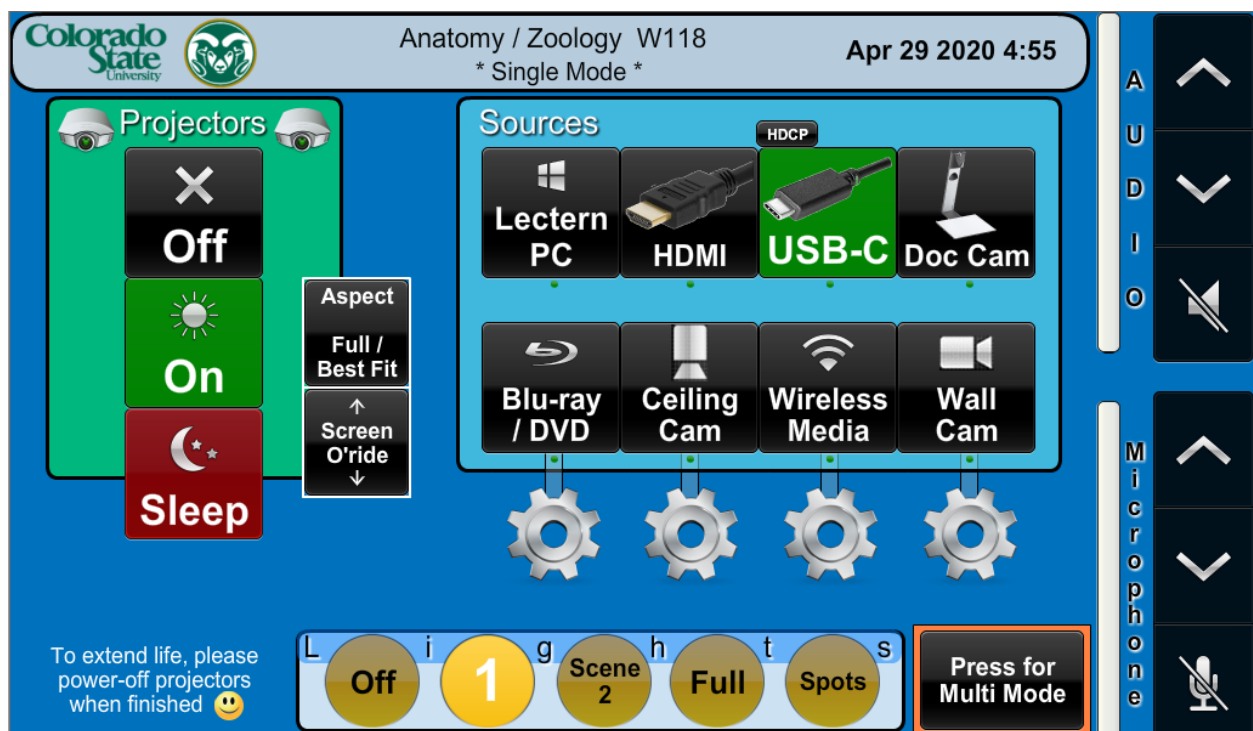

Figure 11 Single Mode Page of the Dual Mode Program

Figure 11 Single Mode Page of the Dual Mode Program shows the single mode page in the dual mode program. This example integrates two projectors.

The two projectors receive the same source image, are controlled identically and the two projector screens operate simultaneously.

A header designation indicates * **Single Mode** * and a button **Press for Multi Mode** is visible.

- When multi mode is not an option, remove this from the single mode page.

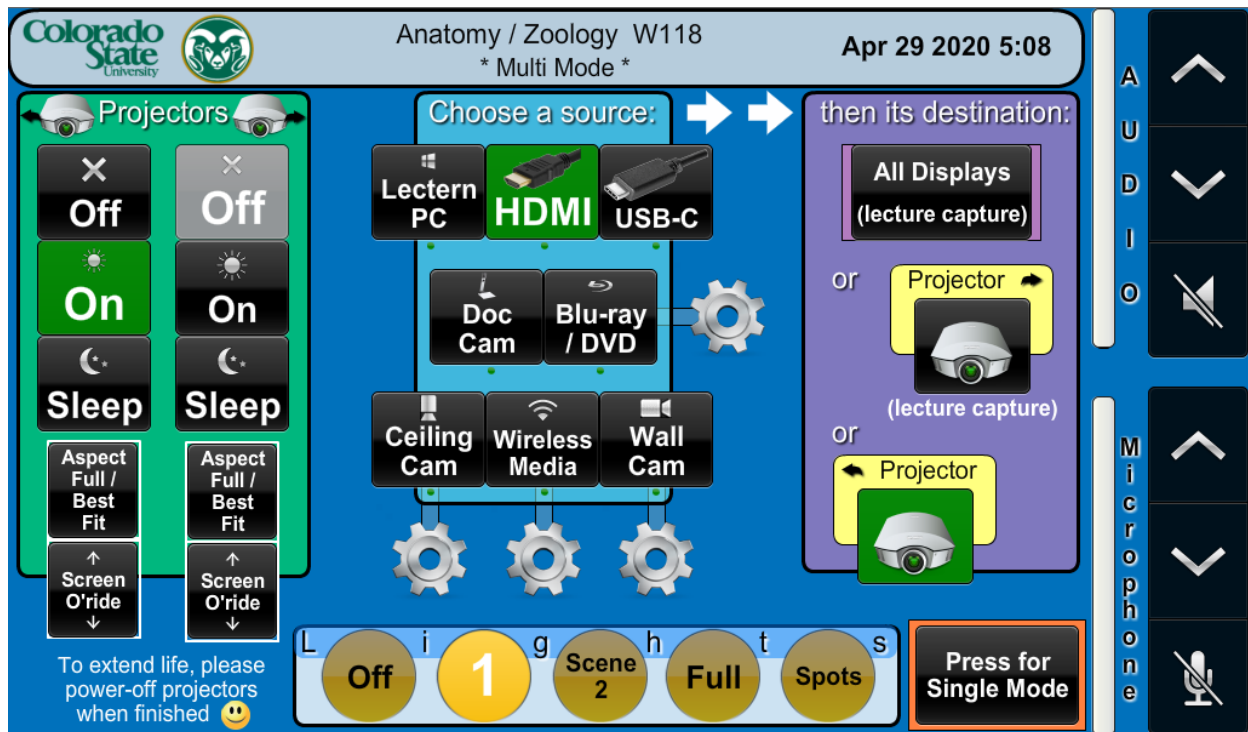

Figure 12: Multi Mode Page of the Dual Mode Program

Figure 12: Multi Mode Page of the Dual Mode Program shows the multi mode page selected by pressing **Press for Multi Mode** shown in Figure 11.

The two projectors can receive separate source images, are controlled individually and the screens operate independently.

A header designation indicates * **Multi Mode** * and a button **Press for Single Mode** is displayed.

If multi mode is not defined then this page is not used.

Options

The layout will be modified to reflect the configuration of the room and will include the available:

- Display type,
- Sources,
- Destinations (multi mode only),
- Aspect ratio,
- Microphone(s),
- Lighting, and
- Electric screen (s).

For example if no microphone is specified then the microphone control is omitted; or if there is no electric screen then the screen override control is omitted.

The displays in Figure 11 are labeled **Projectors**. If the displays were monitors then the label becomes **Displays** with monitor icons alongside.

Off / On Controls

For projectors, **On / Off** controls are used and operated independent of the source / destination controls.

For monitors, omit the **Off** control and set a no-signal power-off timeout on each monitor.

Aspect Ratio

Projection screens are sized for a 16x10 aspect ratio and are imaged with a 16x10 aspect ratio (**Full**) automatically when the projector is powered on.

Some sources will have an aspect ratio other than 16x10 so include the aspect control allowing users to preserve the aspect ratio of the source if so desired (**Best Fit**).

Standard button feedback indication is used.

Alternatively, display devices such as monitors may be sized in a 16x9 aspect ratio.

In this case the aspect control is omitted.

Wall Camera

In this example the wall camera is also the lecture capture camera. It is included as a display source to present demonstrations in larger classrooms.

Smaller classrooms will not have the wall camera available as a source.

Microphones

When more than one microphone is specified, use the microphone volume control for all microphones concurrently.

Requirements

- The project-level theme is Black Glass 2.0.xml from the Crestron standard theme set.
- The CSU logo, room name and current time and date are displayed.
Sync the time and date in the control processor to the CSU timeserver.
- Button clicks are enabled for all controls except as specified.
- Campus network connectivity via static IP addresses is required for all AV components.
- Sources are selected independent of display controls allowing audio-only support from sources and microphones.
- Projector screens are activated both with **Projector Off / On** and with the **Screen O'ride** toggle.

Display Control

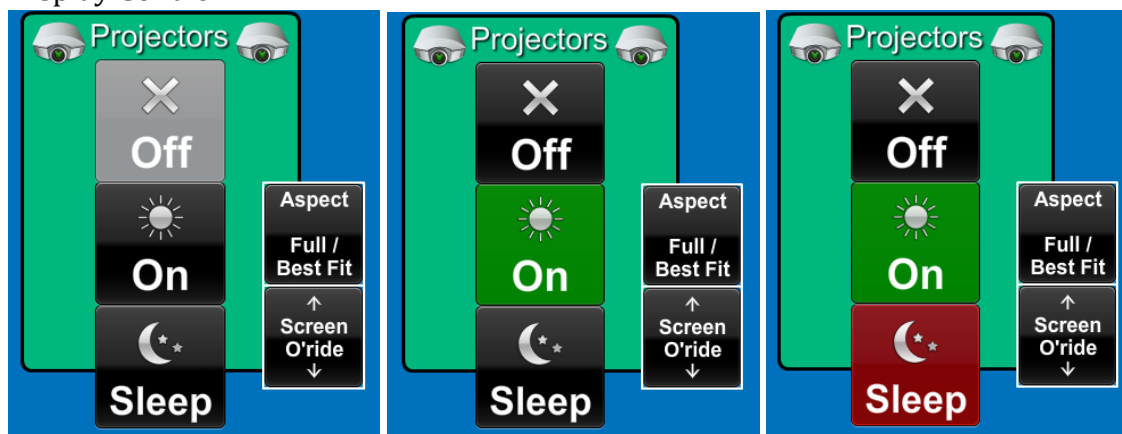

Figure 13: Display Off, Display On, Display Sleep, Aspect and Screen Over-Ride

Figure 13 includes inactive and active button names, colors and icons.

Aspect and **Screen O'ride** have a layout position away from **Off**.

Sleep blanks the display image and is activated only when **On** is active.

When active, **Sleep** flashes on and off, each state once per second, and deactivates either by:

- Pressing **Sleep** again,
- Pressing **Off** or **On** or by
- Pressing any source.

Pressing **Off** or **On** while already active will again send their respective commands to the display device.

Screen O'Ride

Screen up and down occur automatically when the projector is powered off or on.

Screen O'ride allows the screen to deploy or retract independent of the projector's power status.

Source Buttons

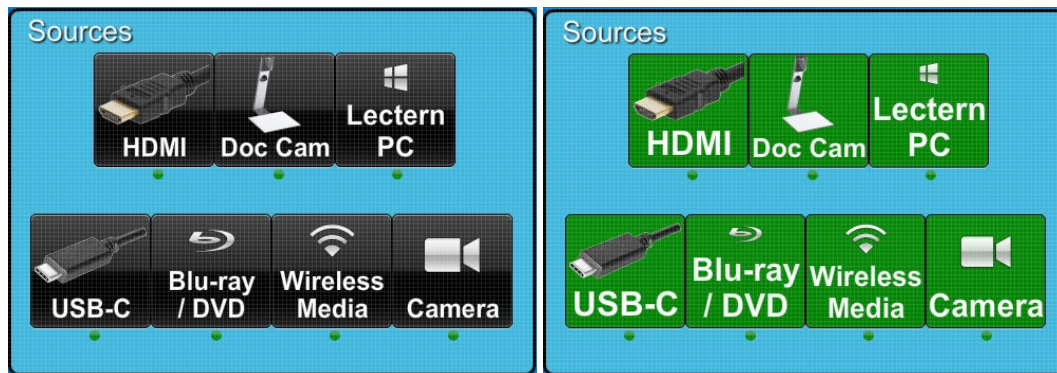

Figure 14: Inactive and Active Source Buttons

Figure 15 shows inactive sources on the left and active sources on the right.

Names, colors and icons are used as shown.

Just one source can be active at a time.

Active source buttons have larger text to help emphasize the selected source.

A 6x6-pixel dot under each button appears when the controller detects a device connected to its associated source input.

Displaying a Source in Matrix Mode



Figure 15: Displaying a Source in Matrix Mode

In matrix mode, display a source first by selecting the source, then its destination.

When a source is selected, all destination buttons show deselected feedback until a destination is selected (Figure 16).

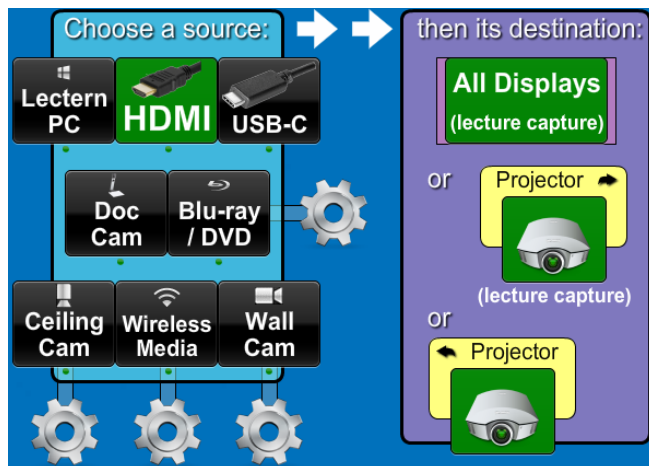

Figure 16: All Destinations with Selected Button Feedback

When **All Displays** is selected, all individual destinations also become selected (Figure 17).

HDCP for User Devices HDMI and USB-C

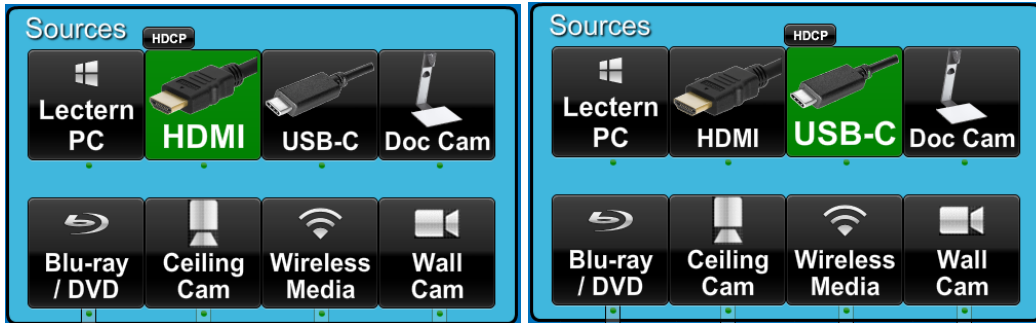

Figure 17: HDCP Indications for HDMI and USB-C Sources

HDCP is disabled by default for sources HDMI and USB-C.

HDCP is enabled by pressing and holding the HDMI or USB-C source button for 3 seconds (Figure 18). When HDCP is enabled the HDCP flag is displayed as shown and flashes on and off, each state once per second.

When any source is subsequently selected, HDCP is disabled and the flag disappears.

Source Pop-up Control Pages

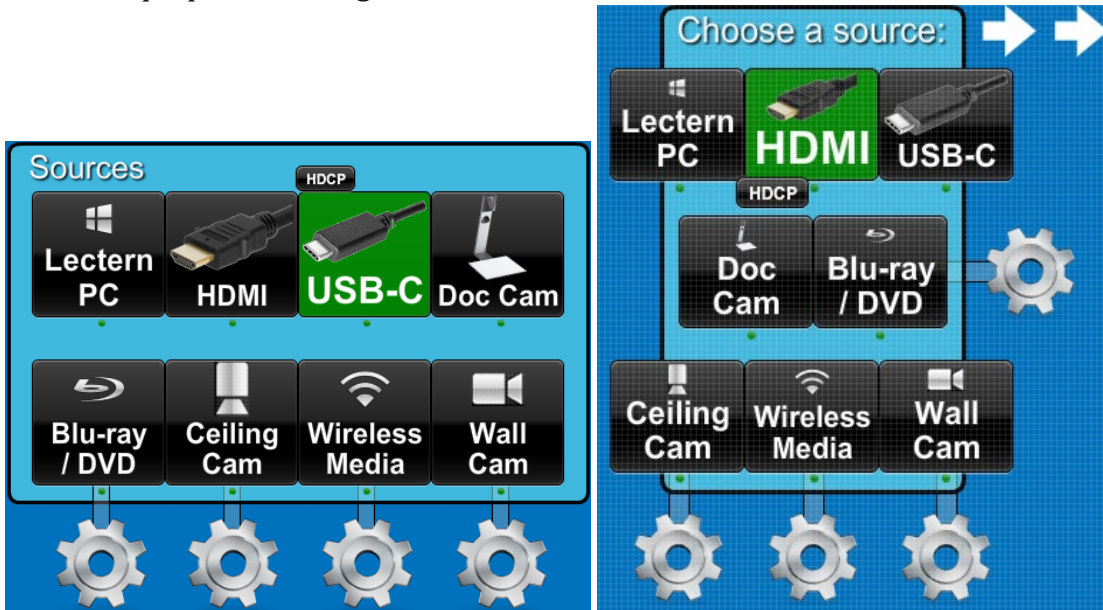

Figure 18: Pop-up Setup Pages

All setup pages for sources are full-page page flips accessed by pressing gear symbol buttons as shown in Figure 19.

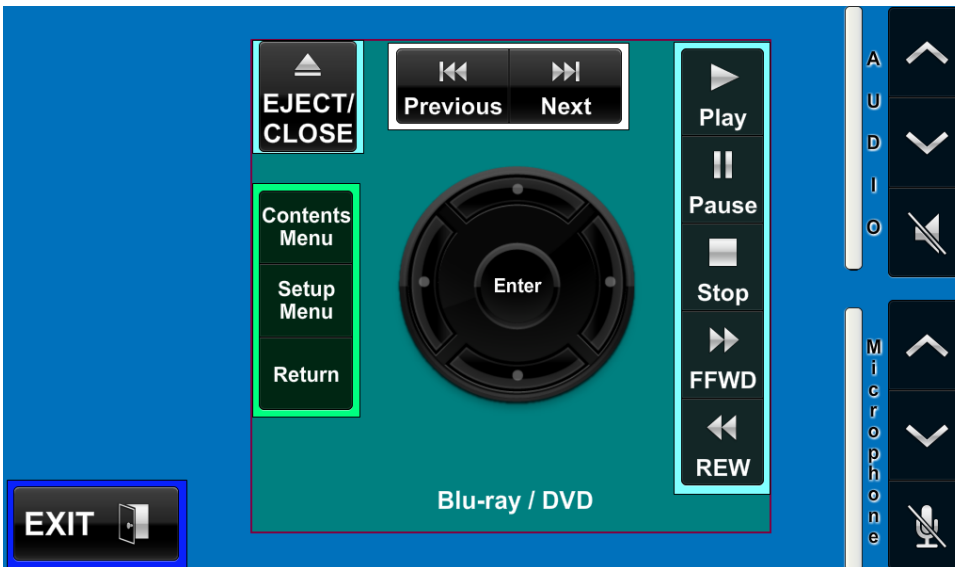

Figure 19: Full-page Blu-ray/DVD Popup

Figure 20 shows the full-page Blu-ray/DVD popup.

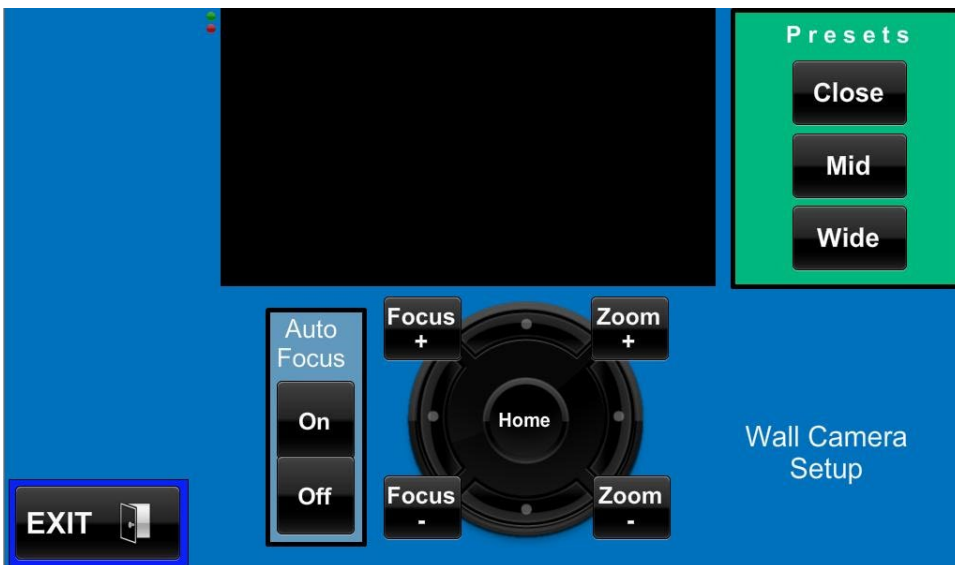

Figure 20: Full-page Wall Camera Setup Pop-up

Figure 21 shows a wall camera setup page for rooms where the camera is a display source.

It contains controls for recalling three non-user-configurable presets.

The camera image is streamed into the (black rectangle) display area.

The green and red dots to the top and left of the display area are made viewable through hooks in the control processor; green indicates a response from the camera's IP address while red indicates no response.

Auto Focus is removed in rooms where the camera is not a display source.

Only the camera image is displayed in small rooms where only one camera shot is anticipated.

Just one non-user-configurable preset is defined and is recalled by the control system approximately every 10 minutes.

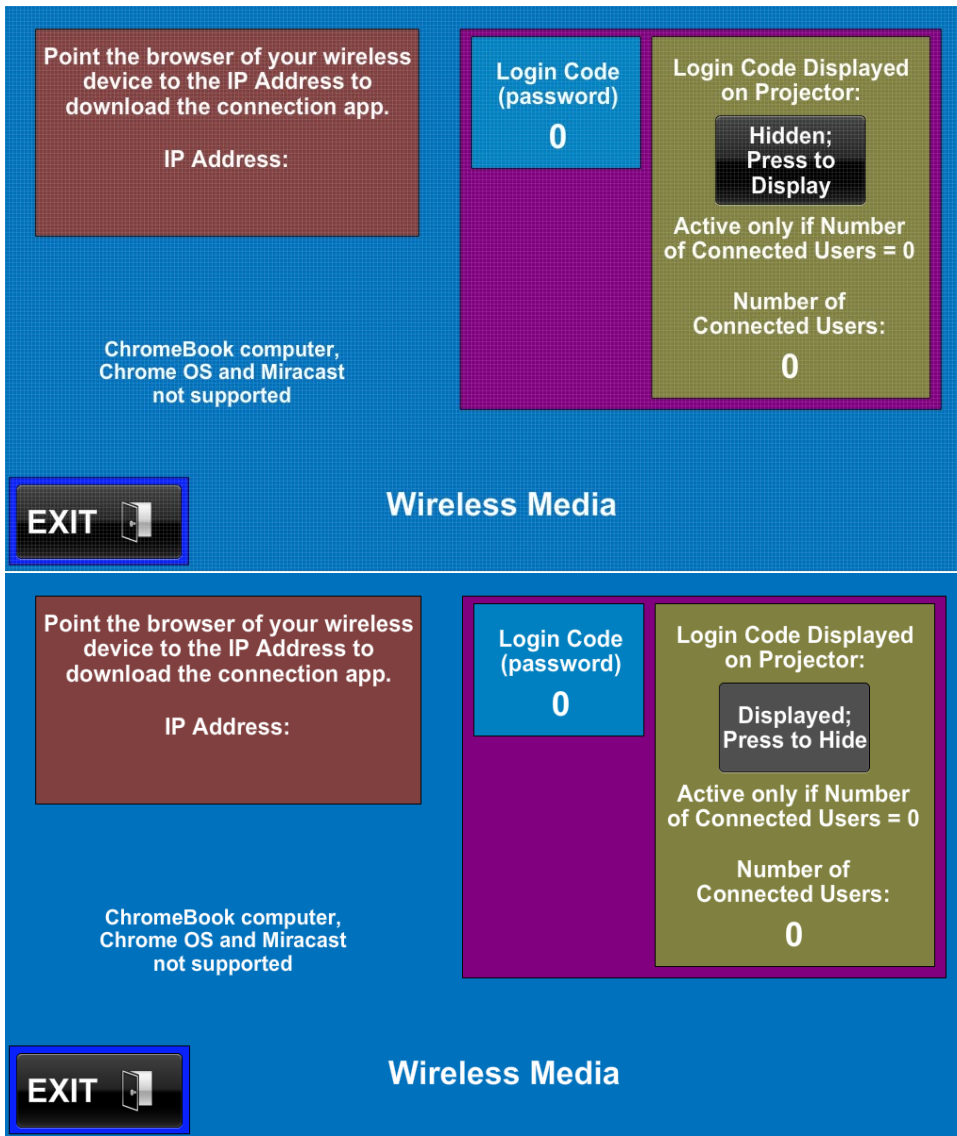

Figure 21: Full-page Wireless Media Setup Pop-up

Figure 22 shows the full-page wireless media setup pop-up. The wireless media popup includes a button for showing or hiding the login code on the room display. **Hidden** is selected by default and reselected automatically after two hours when **Displayed** is selected.

IP Address; **Login Code;** and **Number of Connected Users:** are set in the control processor program. Include other necessary features when available.

Lighting Controls

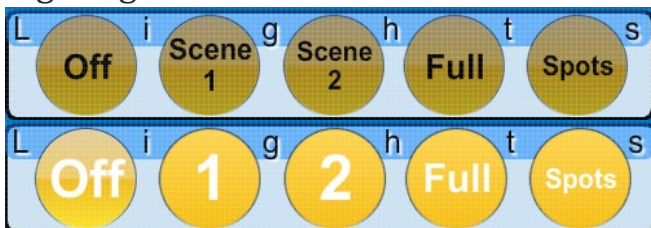

Figure 22: Lighting controls All Deselected and All Selected

Lighting controls are accessed from the main screen. Figure 23 shows all deselected states and all selected states. Just one lighting button can be selected at a time.

External lighting control settings such as near entries are reflected as selection feedback on the user touch panel.

Display On/Off Control

Auto display off time is set to 80 minutes.

Affix a label to the center of the lower bezel "Press panel if no display".

Audio & Microphone Controls

The audio control is for program audio and is used with every system that has room speakers.

The microphone control is included only when presenter voice amplification is specified.



Figure 24 shows active audio and microphone controls.

Mute is selected with button feedback displayed while a red bar appears over the audio level indicator.

Figure 23: Audio Muted

Service Page

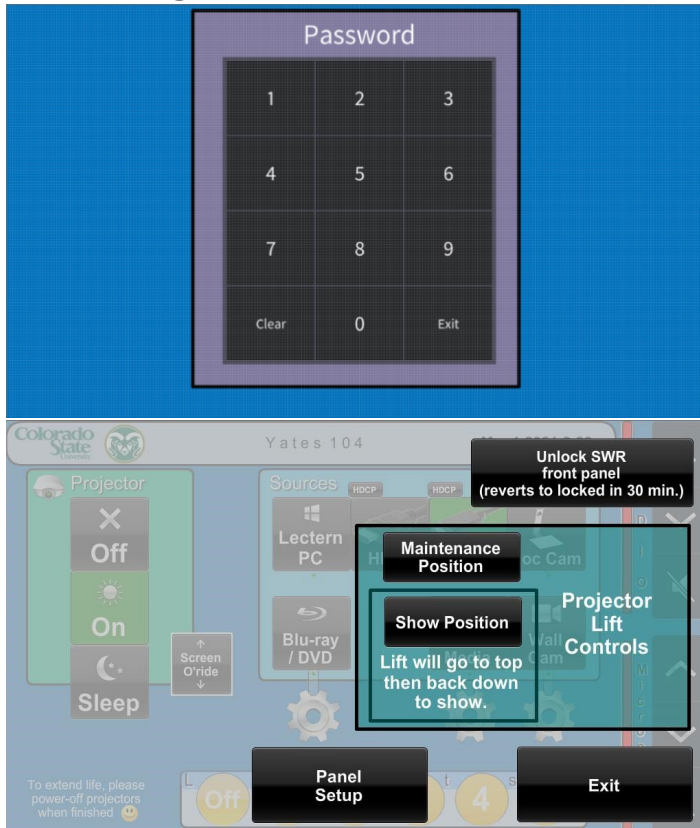

Figure 24 Full-Size Password and Service Pages

The service page is accessed by pressing and holding the CSU logo on the main page for five seconds. Button click is disabled on the CSU logo.

When the password page appears, enter the four-digit password to access the service page (Figure 25).

Features of the service page include:

- Unlocking the switcher front panel:
By default the switcher front panel is locked. Press **Unlock SWR front panel** to unlock it for 30 minutes, after which the front panel locks automatically.
- Projector lift controls:
The projector stays in the show position unless moved into the maintenance position. Control is available only for moving the lift into the service position then returning to the show position.
Hooks exist in the controller program for access to all other lift functions.
- Panel Setup:
This button allows access to the standard panel setup features.

Panel Setup

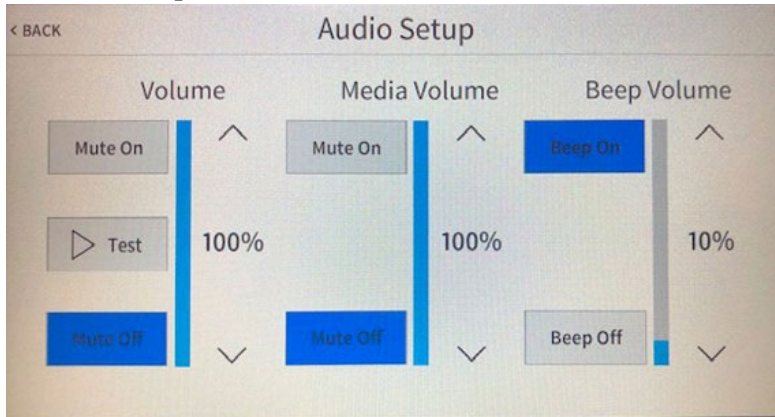

Figure 25 Panel Setup > Audio Setup

Set both Volume and Media Volume to 100% (Figure 26).
Beep volume is set to 10%.

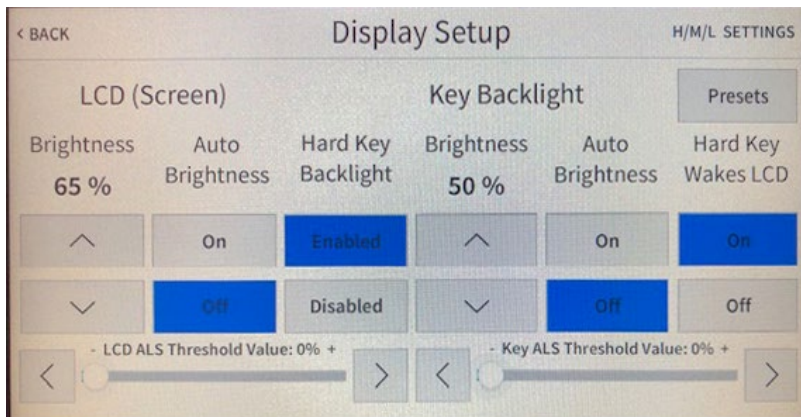

Figure 26 Panel Setup > Display Setup

Auto Brightness is Off and Brightness is set for best presentation (Figure 27).
Hard Key Backlight is Enabled with a Brightness of 50%.
Hard Key Wakes LCD is On.
These settings may need to be defined in the controller program.

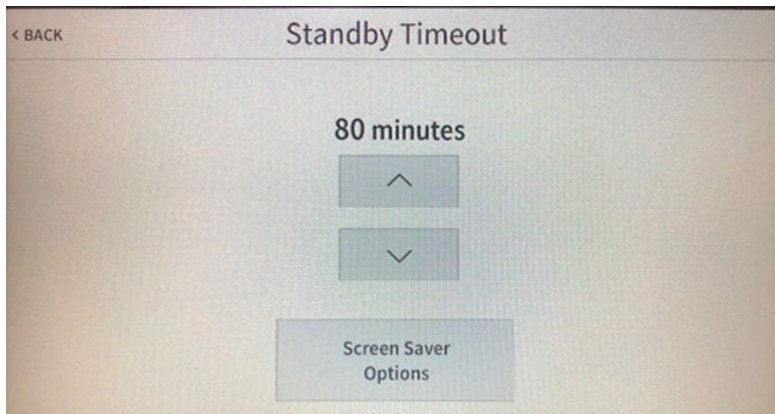

Figure 27 Panel Setup > Standby Timeout

Standby Timeout is 80 minutes (Figure 28).

Automatic Projector Shutdown

Monitor Displays

These instructions do not apply for monitor displays---configure auto-off within the monitor display and disable in the controller program.



Figure 28 Projector Auto-Off Sequence with Center Panel Flash

Automatic projector-off sequence screenshots are shown in Figure 29.

The sequence begins if no touch panel activity is detected for:

- Five hours between 8 AM and 5 PM daily.
- Two hours after 5 PM until 8 AM daily.

The automatic display shutdown sequence is:

1. Simultaneously:
 - The touch panel display appears if off.
 - The auto-off popup page appears, with the center panel flashing on and off, each state once per second.
 - An audible ding is heard and
 - The 5-minute countdown is started and progress displayed at: 5 minutes, 4 minutes, 3 minutes, 2 minutes, then every second counting down from 60.
2. The audible ding repeats at 3 minutes.
3. When 60 seconds begins, the audible recording begins of, "The projector will power down in 60 seconds. Please follow the prompts on the lectern touch panel to continue."
4. At the end of the 60-second count down, simultaneously:
 - The projector begins its power-off cycle

- All pop-up pages close.
- The touch panel display disappears.

If the user intervenes during the countdown by selecting, “Press here to power off the projector now,” then # 4 above is invoked.

If the user intervenes during the countdown by selecting, “Press here to keep the projector on,” then:

- The projector auto-off popup closes.
- The popup in Figure 30 appears for three seconds, “The projector’s on time limit has been extended.”

Hooks are inserted into the controller program to allow for testing of the automatic projector shutdown sequence.

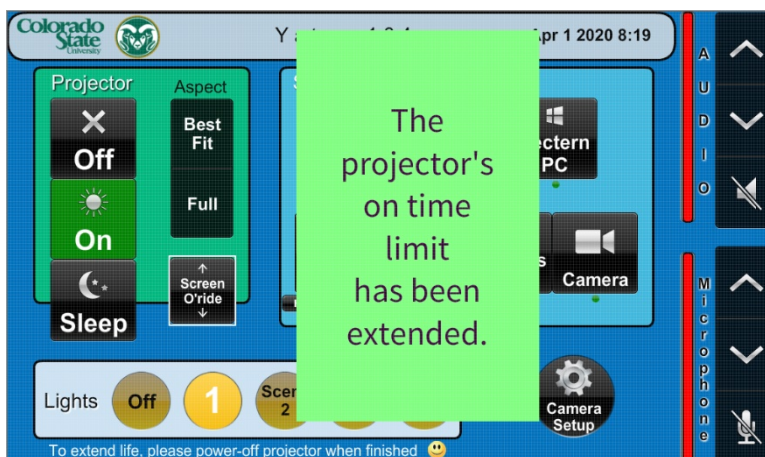

Figure 29 Projector on time extended notification

Audio

Evenly distributed and clearly audible stereo sound is required for both audio program material and wireless microphone audio.

- User control panel program and microphone volume controls, with mute button for each.
- Speakers are not to be located behind or above the lectern to minimize microphone feedback.
- Microphone – Shure QLXD wireless system

Network Design

- No isolated networks.
- CSU Classroom Support and ACNS will assign a static IP address range for all networkable AV equipment (including display devices).
Exceptions (devices not needing an IP address) are wireless mic receivers and Blu-ray decks.
- Authentication enabled on all networked equipment.
- Lectern networking in accordance with standards located on the CSU Telecom website.
- All equipment with network connectors shall be IPV4/IPV6 compatible.
- Each lectern and AV closet housing AV equipment shall contain an appropriately sized managed Ethernet switch specified by CSU Telecom.

- Each data projector location shall have one Ethernet jack installed next to the projector.
- Each room will include an Ethernet jack at the room camera location or at an anticipated location for a future room camera upgrade.

Terminations and Connectors

- RS-232 –soldered DB-9 connectors with proper hoods.
- Crestron DM or Extron XTP cables to be terminated with the EIA/TIA - T568B standard; connections to be tested and verified.

Lighting

- If suspended lighting is used in a classroom, the bottom surface of the lights between the data projector or camera must hang no lower than 12 inches above the center line of the data projector or camera installed in the room, whichever is higher.
- If it is not possible to hang suspended lighting at least 12 inches above the projector or camera, then recessed lighting shall be used for all lights located between the camera and the front of the room in a 60-degree field of view centered on the lectern.
- Suspended lighting fixtures are mounted clear of the sight lines for projectors and cameras.
- Ceiling mounted whiteboard lights are strongly discouraged. If they are used, they must not hang down from the ceiling far enough to intrude into the camera view or the projector image path. They must also be capable of being turned off from the lectern separately from all other room lighting.
- No suspended lighting in any classroom shall hang down from the ceiling far enough to intrude into the camera line of sight or the projector image path. All lights must be mounted at least 12 inches above the centerline of the projector lens.
- Light controls shall be configured so that the row of lights closest to the display screen can be controlled separately from the rest of the room lighting. Using the 50/50 model of light control to enable 50% lighting or no light on that row of lighting is appropriate.
- All classrooms should have the ability to dim the lights nearest to the projection screens, with that control separate from the classroom lighting.
- Light controls shall be provided on the touch panel in each classroom. This shall include the ability to dim the row of lights closest to the data screen independently of other room lights, in order to reduce glare on the screen.

Commissioning

All systems must be checked out fully for functionality, installation integrity and build documentation. All controls and functions in each classroom must be reviewed and approved by CSU Classroom Support Services before signoff.

User Control Panel Checks

- Touch panel labeled.

- Power-on/off projector.
- HDMI AV.
- USB-C AV.
- Doc Cam video
- DVD/Blu-Ray AV
- Projector Sleep On / Off.
- Program and microphone audio up/down and mute on/off.

Controller / Switcher

- Switcher/scaler and source input EDIDs set to the projectors' native resolution.

Projector Checks

- Screen functional and properly positioned.
- Image properly fills the screen on all images.
- Brightness and contrast check.
- Image keystone set.
- Image is sharp and in focus.

Lectern

- Littlite functionality.
- A/C Power in cable nook.
- User Ethernet cable active.
- Two unused, unswitched power outlets.
- Lexan or rack blanks installed in open rack spaces.
- Inside the lectern: wired neatly and clear of extra parts.
- Lectern top clean and void of leftover parts.
- Wires labeled and block diagram provided inside the lectern.

Sign-Off

Device Serial Numbers

Copies of receipts or purchase orders itemizing serial numbers on each device for all Crestron equipment installed must be provided to the CSU Classroom Support Supervisor for CSU to obtain credit with Crestron for equipment purchased.

Review and Approval

All graphics, layout, controls and functions in each classroom must be reviewed and approved by CSU Classroom Support Services.

Programs and Data Handoff

All installation data becomes property of CSU and shall be provided to CSU Classroom Support:

- Controller and touch panel complete program files (including X-panels and all modules).
- Static IP addresses charts.
- Logins and passwords.
- As-built diagrams.

Diagrams and Additional Specifications

- **CSU** Telecom Building Standards <https://telecom.colostate.edu/planning>.
- Lectern Elevation Drawing

RFQ Submittal Requirements for AV Contractors

Colorado State University is soliciting Statements of Qualifications to Audio Visual systems providers / contractors. The A/V provider will be expected to provide and install Audio / Visual equipment during a specific time frame agreed upon, to meet with the Universities requirements. The general specifications and specific requirements of a particular project will be provided by Classroom Support Services / ACNS of Colorado State University. The scope of these projects typically includes small and large Smart Classrooms, as well as video conferencing systems and conference room applications.

General

1. Company history including experience with projects of similar scope.
2. Company Location and travel requirements to complete projects.
3. Company organizational structure and staffing.
4. Staff experience and qualifications.
5. Licensed and or insured installation crew.
6. Available staff to assign to a given project.

Industry Specific

1. List of authorized manufacturer associations.
2. List of A/V certifications and factoring training.
3. List of completed projects (5 minimum) within a 3 – 5 year period.
4. Customer referrals 3 to 5 also within the last 3 – 5 year period.

Project Management

1. Single Project Manager or point of contact.
2. Work completed by company employees – no 3rd party contractors.
3. System Documentation and diagrams (diagrams in Visio format).
4. Wiring and cable labeling that is identifiable within the system diagram.
5. Commitment to provide ongoing project communication and status updates.
6. Meet schedule requirements with system testing and verification upon completion.

Parts List

- CompX brand lock sets, part # C8053-C415A-14A, key C415A.
- Middle Atlantic - CFR14-18 Rack Frame; one per lectern bay.
- Altinex CNK241 Cable Nook Jr.
- RS-232 cabling---Belden 9451- 2 conductor, 22 AWG, stranded, shielded or equivalent.
- Speaker cabling---Belden 5200U or equivalent, minimum 18 gauge.
- Premier PFCMA Ceiling Tile replacement.
- Variable length 1.5" black iron pipe.
- RPM-U Projector Mount (Key Code "A").

16:10 Screens

- Da-Lite screen, Model C w/CSR, 69" x 110", matte white, white case - #34734
- Da-Lite screen, Model B w/CSR, 57.5" x 92", matte white, white case - #36457

Wireless Microphone

- Shure QLX-D1-G50.
- Belt pack QLX-D1.
- Cardioid lavalier WL185.
- Battery SB900.
- Charging dock SBC200-US

Controller

- Crestron DM / DMPS series supporting up to 4K 16x10; WQUXGA.

User Control Panel

- Crestron TS series, standalone-mounted, typically 7”.

Document Camera

- Wolfvision VZ-3neo.

DVD / Blu-Ray Player

- Sony BDP-S6700.

Wireless Presentation

- Crestron AirMedia AM-200.

Audio DSP

- Extron DMP-64.

Lecture Capture

- Echo360 Pod.
- Middle-Atlantic rack shelf- 1RU.
- Neewer Phantom power supply NW-100.
- Rolls Pre-Amp MP13.
- Extron HDMI DA- DA2-HD-4K (60-1480-01).
- Audio Technica U891RbO mounted on lectern.
- PTZ Optics Camera PT12X-SDI-WH-G2 (POE, RTSP).
Auditoriums use PT20x-SDI-WH-G2.

Contacts

Classroom Support Services (CSS)

Allen Sneesby

Clark Building A-69, Campus 0921, Fort Collins, CO 80523-0921 Voice: (970)491-6038

Email: D.Allen.Sneesby@ColoState.EDU

Interim Manager of CSS

Jamie McCue

(970)491-4147

jammccue@colostate.edu

Classroom Support Services is a part of Academic Computing & Networking Services:

<https://www.acns.colostate.edu/classroom-support-services/>